

# FK-5-1-12 CYLINDERS 80 L SINGLE ROW

## AEX/FKB080-(xx)

Specifications								
Reference	Cylinders	Maximum load	L1	L2	L3	L4	Manifold outlet*	Manifol reference*
AEX/FKB080-02	2	192 Kg	334 mm	730 mm	1284 mm	2482 mm	Flange 2 1/2"	CF212S21080
AEX/FKB080-03	3	288 Kg	334 mm	1070 mm	1640 mm	2500 mm	Flange 3"	CF3S31080
AEX/FKB080-04	4	384 Kg	334 mm	1410 mm	1980 mm	2500 mm	Flange 3"	CF3S41080
AEX/FKB080-05	5	480 Kg	334 mm	1750 mm	2352 mm	2546 mm	Flange 4"	CF4S51080
AEX/FKB080-06	6	576 Kg	334 mm	2090 mm	2692 mm	2546 mm	Flange 4"	CF4S61080
AEX/FKB080-07	7	672 Kg	334 mm	2430 mm	3032 mm	2546 mm	Flange 4"	CF4S71080
AEX/FKB080-08	8	768 Kg	406 mm	2770 mm	3397 mm	2591 mm	Flange 5"	CF5S81080
AEX/FKB080-09	9	864 Kg	406 mm	3110 mm	3737 mm	2591 mm	Flange 5"	CF5S91080
AEX/FKB080-10	10	960 Kg	406 mm	3450 mm	4077 mm	2591 mm	Flange 5"	CF5S101080
AEX/FKB080-11	11	1056 Kg	406 mm	3790 mm	4433 mm	2621 mm	Flange 6"	CF6S111080
AEX/FKB080-12	12	1152 Kg	406 mm	4130 mm	4773 mm	2621 mm	Flange 6"	CF6S121080
AEX/FKB080-13	13	1248 Kg	406 mm	4470 mm	5113 mm	2621 mm	Flange 6"	CF6S131080
AEX/FKB080-14	14	1344 Kg	406 mm	4810 mm	5453 mm	2621 mm	Flange 6"	CF6S141080

\*The manifold diameter may vary depending on the hydraulic calculations of each installation.

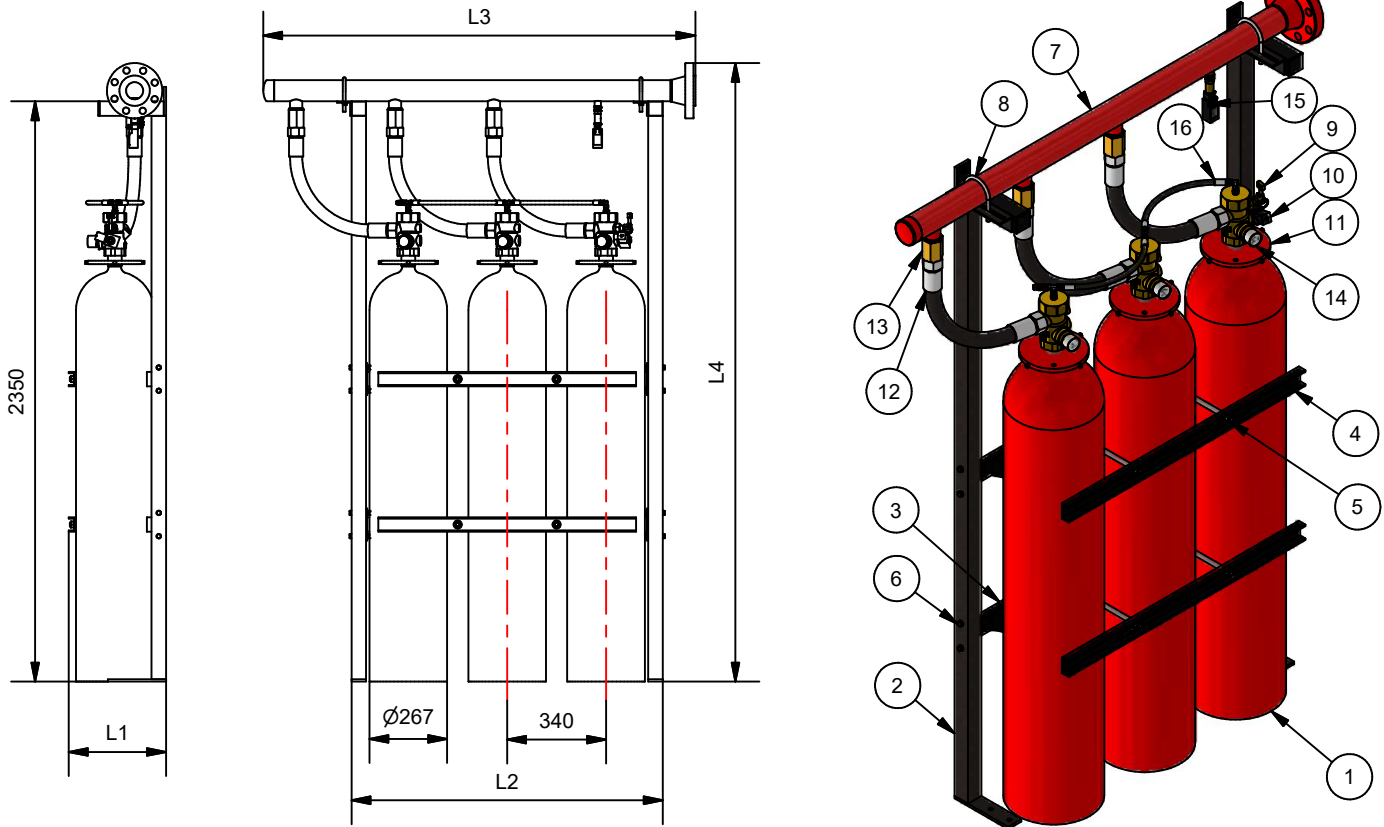

Parts List		Parts List	
Number	Reference and description	Number	Reference and description
1	BFE80 - Cylinder 80 L	9	AEX/PM160A - Manual lever
2	HP-2350 - Single row battery foot	10	AEX/NKVS24 - Solenoid
3	HTP(x) - Rear cross member (x) cylinders	11	BRR212 - Flange 2 1/2 " for cylinder
4	HTA(x) - Front cross member (x) cylinders	12	L112N - Flexible hose discharge 1 1/2"
5	HV - Single row battery separator rod	13	AEX/VAR112 - Check valve 1 1/2"
6	TO8M70 - M8 Screws, nuts and washers	14	AEX/FKMCNC42 - Pressure gauge
7	VER TABLA - Manifold	15	AEX/CP1 - Step contactor (optional)
8	HA(x) - Strut (x)"	16	LD18 - Trip Hose 1/8"



Av. Alfonso Peña Boeuf, 6 y 9  
28022 MADRID - ESPAÑA  
TEL: +34 913121656  
FAX: +34 913295820

### TECHNICAL DATA SHEET

#### FK-5-1-12 CYLINDERS 80 L SINGLE ROW

Description: Complete cylinder bank, equipped with manual and electric actuator, pressure gauges, hoses and manifold.

Sheet code:	Solution sheet:	Reference:	Drawn:	Date:	Revised:	Date:	Revision:	Format:
AEX-FTC-61-006	FK-5-1-12	AEX/FKB080-(xx)	DCM	12-09-23	ENC	12-09-23	1.1	A4